

TA20.30.T

caratteristiche/features



peso/weight



rotazione/rotation



prestazioni/performances

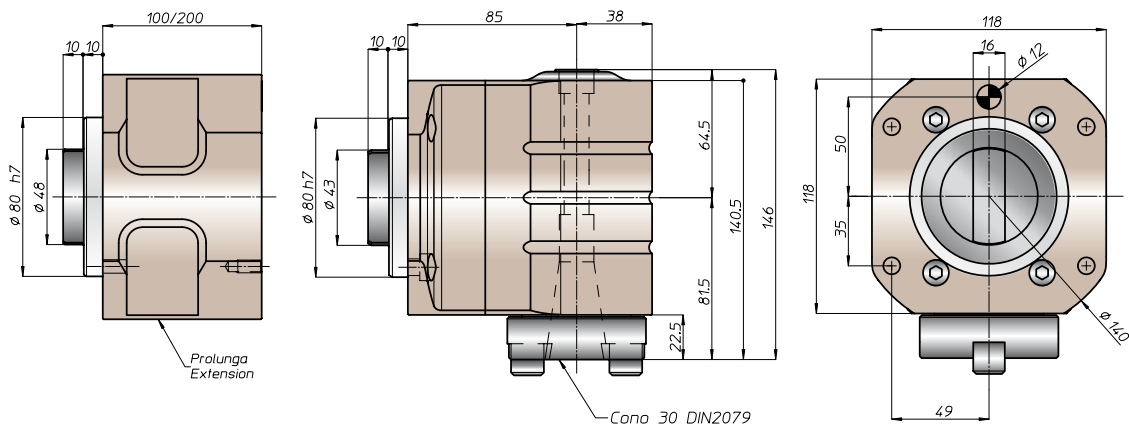
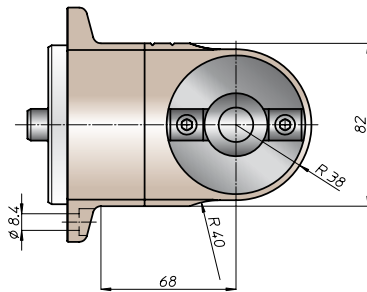
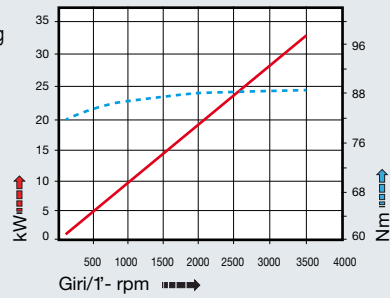

Nota:

- nel mandrino DIN2079 si possono utilizzare coni DIN2080-30, DIN69871-A30, MAS403-BT30

Note:

- on the spindle DIN2079 you can use shank DIN2080-30, DIN69871-A30, MAS403-BT30

esempio di collegamento - connection example

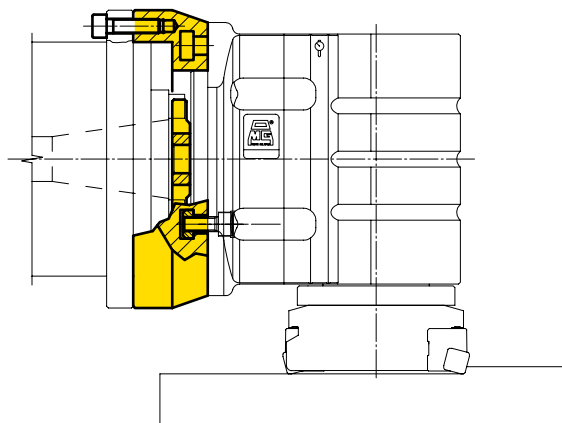

BAH

TA.CP

TA

MO

HT

VH

TSI/TSX

T

MT-TC-TC3

Accessori
Accessories

Appendice tecnica
Technical supplement

