

等高粗搪頭系統組合(雙刃等高切削相同直徑)

SACC and SACC Cutting Insert Holders have the same Cutting Diameter and Height.

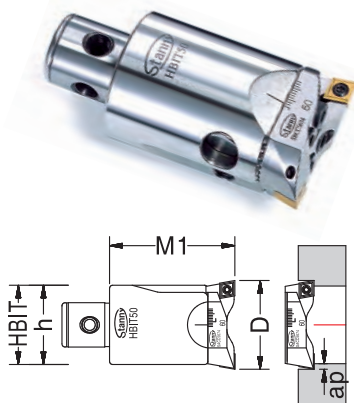

訂貨編號 Order No.	規格 Model	範圍 D Boring Range øDMin-øDMax	M1	h	粗搪孔刀本體 Boring Head	粗搪孔刀座 Cutting Insert Holder	淨重 N.W.	
32290000AA	HBIT25 AA	29-36	50	25	HBIT25	SACC2936	SACC2936	0.17
32350000AA	HBIT25 AA	35-42				SACC3542	SACC3542	0.19
33360000AA	HBIT32 AA	36-45	63	32	HBIT32	SACC3645	SACC3645	0.37
33440000AA	HBIT32 AA	44-53				SACC4453	SACC4453	0.37
34450000AA	HBIT40 AA	45-56	63	40	HBIT40	SACC4556	SACC4556	0.56
34550000AA	HBIT40 AA	55-66				SACC5566	SACC5566	0.58
35560000AA	HBIT50 AA	56-74	80	50	HBIT50	SACC5674	SACC5674	1.10
35740000AA	HBIT50 AA	74-92				SACC7492	SACC7492	1.14
36700000AA	HBIT63 AA	70-90	80	63	HBIT63	SACC7090	SACC7090	1.78
36900000AA	HBIT63 AA	90-110				SACC90110	SACC90110	1.90
38900000AA	HBIT80 AA	90-130	82	63	HBIT80	SACC90130	SACC90130	2.30
38910000AA	HBIT80 AA	130-170				SACC130170	SACC130170	2.44
38920000AA	HBIT80 AA	170-210	80	80	HBIT80E	SACC170210	SACC170210	2.64
38900000EAA	HBIT80E AA	90-130				SACC90130	SACC90130	2.76
38910000EAA	HBIT80E AA	130-170	80	80	HBIT80E	SACC130170	SACC130170	2.90
38920000EAA	HBIT80E AA	170-210				SACC170210	SACC170210	3.10
39130000AA	HBIT120 AA	130-190	100	100	HBIT120	SACC130190	SACC130190	6.67
39170000AA	HBIT120 AA	170-230				SACC170230	SACC170230	6.89

不等高粗搪頭系統組合(雙刃不等高切削不同直徑)

SACC and SBCC Cutting Insert Holders have different Cutting Diameter and Height.

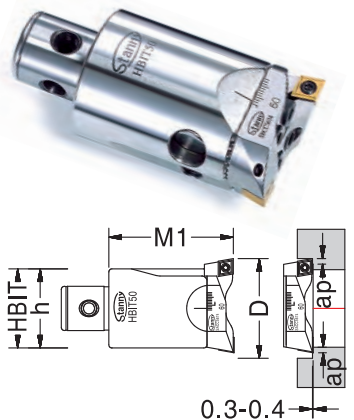

訂貨編號 Order No.	規格 Model	範圍 D Boring Range øDMin-øDMax	M1	h	粗搪孔刀本體 Boring Head	粗搪孔刀座 Cutting Insert Holder	淨重 N.W.	
32290000AB	HBIT25 AB	29-36	50	25	HBIT25	SACC2936	SBCC2936	0.17
32350000AB	HBIT25 AB	35-42				SACC3542	SBCC3542	0.19
33360000AB	HBIT32 AB	36-45	63	32	HBIT32	SACC3645	SBCC3645	0.37
33440000AB	HBIT32 AB	44-53				SACC4453	SBCC4453	0.37
34450000AB	HBIT40 AB	45-56	63	40	HBIT40	SACC4556	SBCC4556	0.56
34550000AB	HBIT40 AB	55-66				SACC5566	SBCC5566	0.58
35560000AB	HBIT50 AB	56-74	80	50	HBIT50	SACC5674	SBCC5674	1.10
35740000AB	HBIT50 AB	74-92				SACC7492	SBCC7492	1.14
36700000AB	HBIT63 AB	70-90	80	63	HBIT63	SACC7090	SBCC7090	1.78
36900000AB	HBIT63 AB	90-110				SACC90110	SBCC90110	1.90
38900000AB	HBIT80 AB	90-130	82	63	HBIT80	SACC90130	SBCC90130	2.30
38910000AB	HBIT80 AB	130-170				SACC130170	SBCC130170	2.44
38920000AB	HBIT80 AB	170-210	80	80	HBIT80E	SACC170210	SACC170210	2.63
38900000EAB	HBIT80E AB	90-130				SACC90130	SBCC90130	2.76
38910000EAB	HBIT80E AB	130-170	80	80	HBIT80E	SACC130170	SBCC130170	2.90
38920000EAB	HBIT80E AB	170-210				SACC170210	SBCC170210	3.09
39130000AB	HBIT120 AB	130-190	100	100	HBIT120	SACC130190	SACC130190	6.66
39170000AB	HBIT120 AB	170-230				SACC170230	SBCC170230	6.88

80°等高粗搪頭系統組合(雙刃等高切削相同直徑)

EMSC and EMSC 80° Cutting Insert Holders have the same Cutting Diameter and Height.

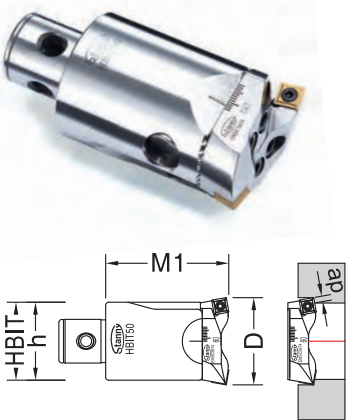

訂貨編號 Order No.	規格 Model	範圍 D Boring Range øDMin-øDMax	M1	h	粗搪孔刀本體 Boring Head	80° 粗搪孔刀座 80° Cutting Insert Holder	淨重 N.W.	
32290000MM	HBIT25 MM	29-36	50	25	HBIT25	EMSC2936	EMSC2936	0.17
32350000MM	HBIT25 MM	35-42				EMSC3542	EMSC3542	0.17
33360000MM	HBIT32 MM	36-45	63	32	HBIT32	EMSC3645	EMSC3645	0.35
33440000MM	HBIT32 MM	44-53				EMSC4453	EMSC4453	0.37
34450000MM	HBIT40 MM	45-56	63	40	HBIT40	EMSC4556	EMSC4556	0.54
34550000MM	HBIT40 MM	55-66				EMSC5566	EMSC5566	0.56
35560000MM	HBIT50 MM	56-74	80	50	HBIT50	EMSC5674	EMSC5674	1.08
35740000MM	HBIT50 MM	74-92				EMSC7492	EMSC7492	1.14
36700000MM	HBIT63 MM	70-90	80	63	HBIT63	EMSC7090	EMSC7090	1.78
36900000MM	HBIT63 MM	90-110				EMSC90110	EMSC90110	1.90
38900000MM	HBIT80 MM	90-130	82	63	HBIT80	EMSC90130	EMSC90130	2.30
38910000MM	HBIT80 MM	130-170				EMSC130170	EMSC130170	2.42
38900000EMM	HBIT80E MM	90-130	80	80	HBIT80E	EMSC90130	EMSC90130	2.76
38910000EMM	HBIT80E MM	130-170				EMSC130170	EMSC130170	2.88
39130000MM	HBIT120 MM	130-190	100	100	HBIT120	EMSC130190	EMSC130190	6.67
39170000MM	HBIT120 MM	170-230				EMSC170230	EMSC170230	6.89

HBIT

粗搪孔刀本體、45°正反倒角粗搪孔刀座 Body and 45° Chamfer Cutting Insert Holder 粗搪孔刀本體、粗搪孔反搪刀座 Body and Reverse Cutting Insert Holder

45°正反倒角粗搪頭系統組合 Body and 45° Chamfer Cutting Insert Holder

訂貨編號 Order No.	規格 Model	範圍 D Boring Range øDMin-øDMax	M1	h	粗搪孔刀本體 Boring Head	45°正反倒角刀座 45° Chamfer Cutting Insert Holder	壓板 Apron	淨重 N.W.
32290000AW	HBIT25 AW	29-36	50	25	HBIT25	IWSC2936	apr25	0.17
32350000AW	HBIT25 AW	35-42				IWSC3542		0.17
33360000AW	HBIT32 AW	36-45	63	32	HBIT32	IWSC3645	apr32	0.35
33440000AW	HBIT32 AW	44-53				IWSC4453		0.36
34450000AW	HBIT40 AW	45-56	80	40	HBIT40	IWSC4556	apr40	0.53
34550000AW	HBIT40 AW	55-66				IWSC5566		0.54
35560000AW	HBIT50 AW	56-74	100	50	HBIT50	IWSC5674	apr50	1.06
35740000AW	HBIT50 AW	74-92				IWSC7492		1.09
36700000AW	HBIT63 AW	70-90	80	63	HBIT63	IWSC7090	apr63	1.72
36900000AW	HBIT63 AW	90-110				IWSC90110		1.78
38900000AW	HBIT80 AW	90-130	100	80	HBIT80	IWSC90130	apr80	2.21
38910000AW	HBIT80 AW	130-170				IWSC130170		2.27
38900000EAW	HBIT80E AW	90-130	80	80	HBIT80E	IWSC90130	apr80	2.67
38910000EAW	HBIT80E AW	130-170				IWSC130170		2.73
39130000AW	HBIT120 AW	130-190	100	100	HBIT120	IWSC130190	apr120	6.48
39170000AW	HBIT120 AW	170-230				IWSC170230		6.59

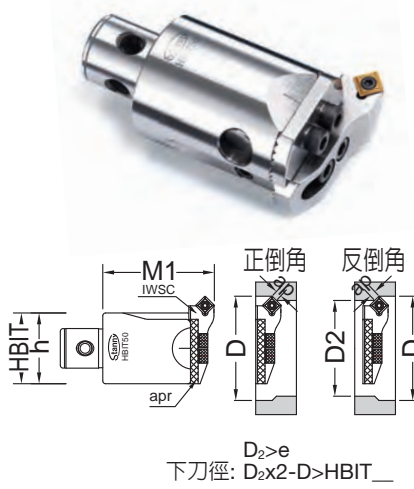

粗搪反搪孔頭系統組合 Body and Reverse Cutting Insert Holder

訂貨編號 Order No.	規格 Model	範圍 D Boring Range øDMin-øDMax	M3	M2	h	粗搪孔刀本體 Boring Head	粗搪孔反搪刀座 Reverse Cutting Insert Holder	壓板 Apron	淨重 N.W.
32290000AK	HBIT25 AK	29-36	2-5	40	25	HBIT25	RKCC2936	apr25	0.17
32350000AK	HBIT25 AK	35-42	5-8				RKCC3542		0.18
33360000AK	HBIT32 AK	36-45	2-6	50	32	HBIT32	RKCC3645	apr32	0.36
33440000AK	HBIT32 AK	44-53	6-10				RKCC4453		0.36
34450000AK	HBIT40 AK	45-56	2-8	48	40	HBIT40	RKCC4556	apr40	0.54
34550000AK	HBIT40 AK	55-66	7-13				RKCC5566		0.55
35560000AK	HBIT50 AK	56-74	3-12	62	50	HBIT50	RKCC5674	apr50	1.07
35740000AK	HBIT50 AK	74-92	12-21				RKCC7492		1.09
35750000AK	HBIT50 AK	92-110	21-30	58	63	HBIT63	RKCC92110	apr63	1.13
35760000AK	HBIT50 AK	110-128	30-39				RKCC110128		1.15
35770000AK	HBIT50 AK	128-146	39-48	73	100	HBIT120	RKCC128146	apr120	1.17
36700000AK	HBIT63 AK	70-90	3-13				RKCC7090		1.74
36900000AK	HBIT63 AK	90-110	13-23	58	63	HBIT63	RKCC90110	apr63	1.79
36910000AK	HBIT63 AK	110-130	23-33				RKCC110130		1.85
36920000AK	HBIT63 AK	130-150	33-43	58	80	HBIT80E	RKCC130150	apr80	1.89
36930000AK	HBIT63 AK	150-170	43-53				RKCC150170		1.94
38900000AK	HBIT80 AK	90-130	5-25	73	100	HBIT120	RKCC90130	apr120	2.23
38910000AK	HBIT80 AK	130-170	25-45				RKCC130170		2.30
38920000AK	HBIT80 AK	170-210	45-65	58	80	HBIT80E	RKCC170210	apr80	2.41
38900000EAK	HBIT80E AK	90-130	5-25				RKCC90130		2.69
38910000EAK	HBIT80E AK	130-170	25-45	73	100	HBIT120	RKCC130170	apr120	2.70
38920000EAK	HBIT80E AK	170-210	45-65				RKCC170210		2.87
39130000AK	HBIT120 AK	130-190	5-35	73	100	HBIT120	RKCC130190	apr120	6.49
39170000AK	HBIT120 AK	170-230	25-55				RKCC170230		6.59

