

HBOR63P

極細微調精搪孔系統－菱形

Micro-Finishing Cutter for Rhombus Fine Boring System

整組SET G2.5 12000rpm $\phi 11 \sim \phi 150$

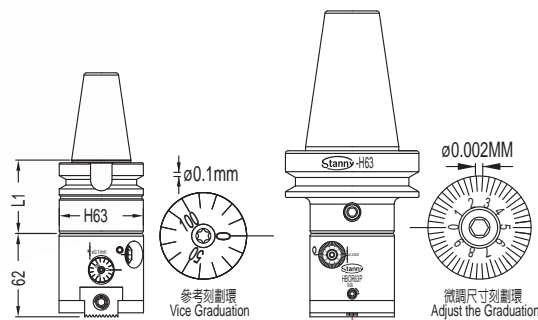

訂貨編號 Order No.	規格 Model	範圍 D Boring Range $\phi D_{Min} \sim \phi D_{Max}$	組合系統-主軸柄規格 Taper Shank	L1	淨重 N.W.
56801405RM	BT40-HBOR63P	11-150	MAS403 BT40-H63-55	55	8.4
56801506RM	BT50-HBOR63P	11-150	MAS403 BT50-H63-65	65	10.9
56801508RM	BT50-HBOR63P	11-150	MAS403 BT50-H63-85	85	11.4
56802406RM	SK40-HBOR63P	11-150	DIN69871A ISO40-H63-60	60	8.4
56802506RM	SK50-HBOR63P	11-150	DIN69871A ISO50-H63-65	65	10.0
56804606RM	HSK63-HBOR63P	11-150	DIN69893A HSK63-H63-67	67	8.3

接桿 Shank

訂貨編號 Order No.	規格 Model	X	深度 DM	C導程螺帽 C-NUT	螺絲 B-Bolt	扳手 Wrench	淨重 N.W.
50171004	BRM1610-40	45	41	NUT6	SLCS-M3	T8	0.07
50171205	BRM1612-50	54	51	NUT7	SLCS-M4	T15	0.09
50171405	BRM1614-55	59	56				0.11
50171606	BRM1616-65	67	66	NUT9	SLCS-M5	T25	0.14
50172008	BRM1620-80	82	81				0.22
50172510	BRM1625-100	102	101				0.41
50162510	BM5-100L	96	88+		M5×12	○4	0.40
50501608	BM8				M8×20	○6	0.03

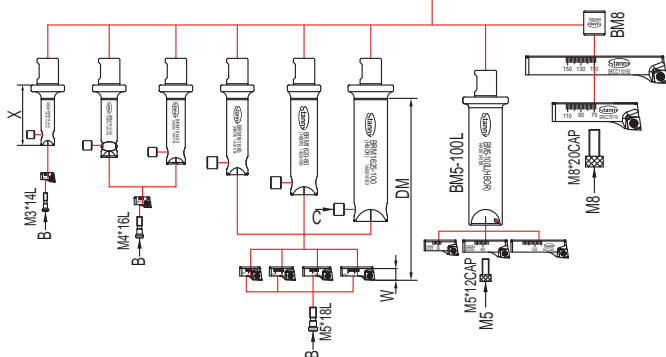

搪孔刀座 Cutting Insert Holder

訂貨編號 Order No.	規格 Model	範圍 D Boring Range $\phi D_{Min} \sim \phi D_{Max}$	刀座高度 W	接桿 Shank	刀片 Insert	螺絲 Bolt	扳手 Wrench	淨重 N.W.
50061114	MR11	11-14	6	BRM1610-40	CCGT0301..L	SB-1630TR-M1.6	T6	0.002
50061317	MR13	13-17	7	BRM1612-50 BRM1614-55	CCGT0401..L	SB-2040TR-M2		0.003
50061723	MR17	17-23	9	BRM1616-65 BRM1620-80 BRM1625-100	CCGT0602..L	TS25-M2.5	T8	0.005
50062026	MR20	20-26						0.006
50062329	MR23	23-29						0.008
50062632	MR26	26-32						0.009
50252938CC	SRCC2938	29-38	11	BM5-100L				0.010
50323652CC	SRCC3652	36-52	13					0.020
50404468CC	SRCC4468	44-68	13					0.030
50637011CC	SRCC70110	70-110	20	BM8	CCGT09T3..L	TS4-M4	T15	0.100
50637115CC	SRCC110150	110-150	20					0.210