

T22-TS22

Codice testa
Head code

Codice mandrino
Spindle code

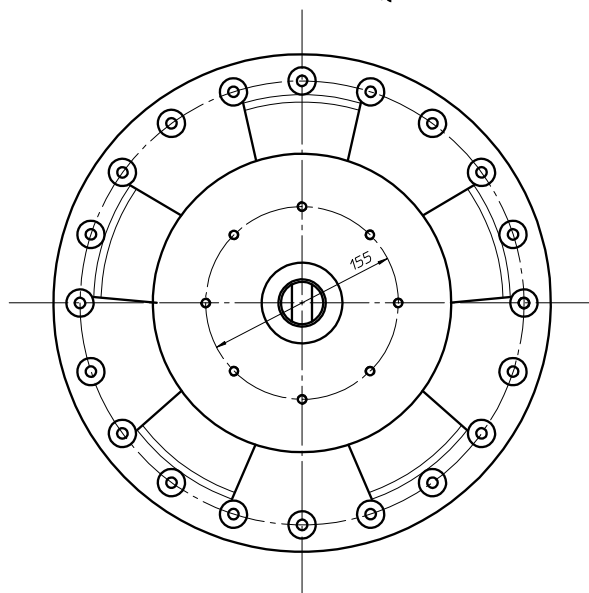
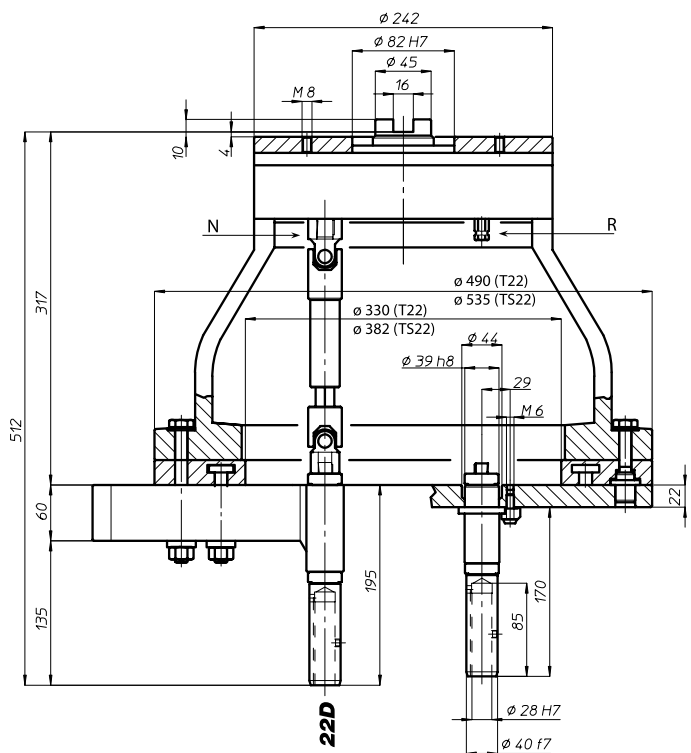
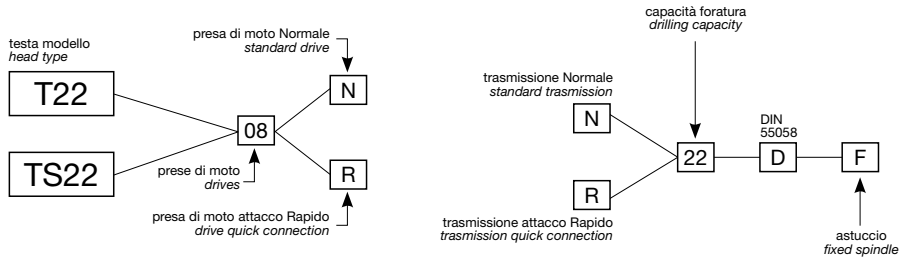

	N° prese di moto Nr. spindle drives	08
	Rapporto Ratio	1-1
	Capacità di foratura Drilling capacity acciaio R=500 N/mm ² ghisa: GG25	20 22
	Maschiatura Tapping	M16
	Attacco utensile Type of spindle D	DIN 55058 Ø28
	Peso gruppo testa Head weight	T22: Kg 38,5 TS22: Kg 41
	Peso gruppo mandrino Spindle-set weight	Kg 5,5

area di lavoro
working area

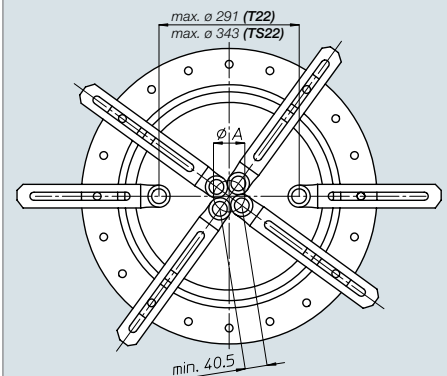

ϕA	n° mandrini n° spindles
47,5	3
58	4
69,5	5
81,5	6
94	7
106,5	8



BAH

TA-CP

TA

MO

HT

VH

TSI/TSX

T

MT-TC-TC3

Accessori
Accessories

Appendice tecnica
Technical supplement

8-9