

# T7

Codice testa  
Head code

Codice mandrino  
Spindle code

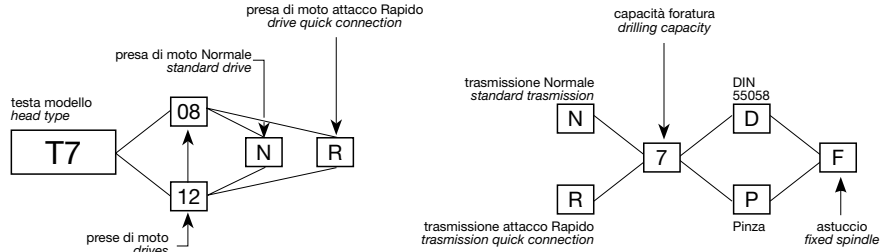

N° prese di moto  
Nr. spindle drives

08-12

Rapporto  
Ratio

1-1

Capacità di foratura  
Drilling capacity  
acciaio R=500 N/mm<sup>2</sup>  
ghisa: GG25

6  
7

Maschiatura  
Tapping

M5

Attacco utensile  
Type of spindle

D  
P

DIN 55058 Ø10  
ER11

Peso gruppo testa  
Head weight

Kg 10

Peso gruppo mandrino  
Spindle-set weight

Kg 1,1

## area di lavoro working area

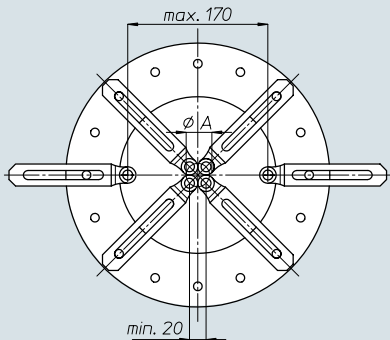

ø A	n° mandrini n° spindles
23,5	3
28,5	4
34,5	5
40,5	6
46,5	7
52,5	8
59	9
65,5	10
71,5	11
77,5	12

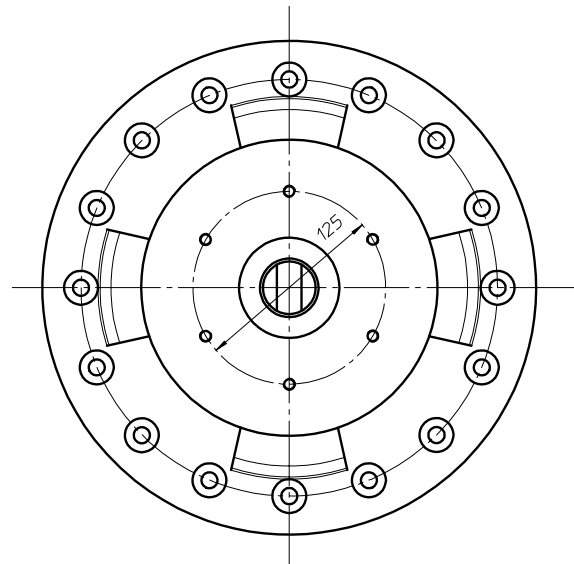
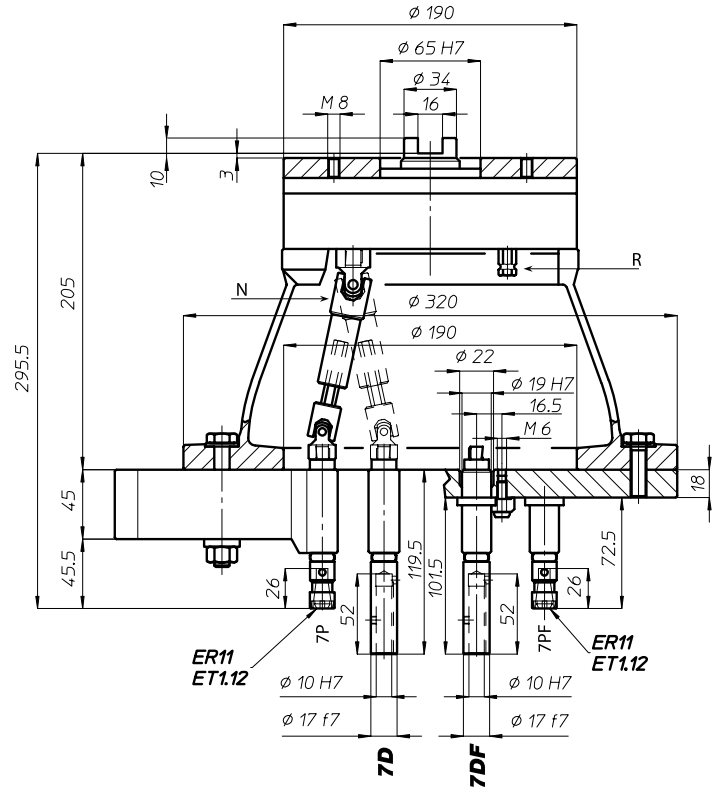

BAH

TA-CP

TA

MO

HT

VH

TSI/TSX

T

MT-TC-TC3

Accessori  
Accessories

Appendice tecnica  
Technical supplement

8-4

