

MC 定壓式倍力虎鉗 MC POWER VISE

MODEL : JQV-160S、JQV-160M、JQV-160、JQV-160L、JQV-200L



特點：

1. 定壓裝置，夾持力可以預先設定，重複使用相同的夾持力。
2. 虎鉗本台採用球狀石墨化鑄鐵FCD-60材質。
3. 虎鉗滑動面均經硬化熱處理HRC45°，堅固耐用確保精度。
4. 虎鉗本體的高度與導正鍵槽皆做定寸管制，可以2、3、4台一起使用。
5. 虎鉗本體長度超短，開口超大，適合各式銑床、中心加工機使用。



★虎鉗可側立使用
VISE CAN SIDE-LOCK TO WORK.

FEATURES :

1. Pressure Constant. Clamping force can presetting, repeat use the same clamping force.
2. Vise body is made of ductile iron FCD-60.
3. Vise bed hardened to HRC45° and maintain accuracy for long.
4. Vise bed height-size and the guide block side are all made with full control, can 2、3、or 4 vises to perform a job at a time.
5. The length of vise body is very short, but the clamping range is very big. It works with every kind of milling machine, CNC machine center...

★每台虎鉗的高度與導正鍵槽皆做定寸管制。
The height and the guide block side of every vise are all made with full control.

L-尺寸公差限度0.02或少於 H- Dimension tolerance 0.02
L- Dimension tolerance 0.02 or less. or less.

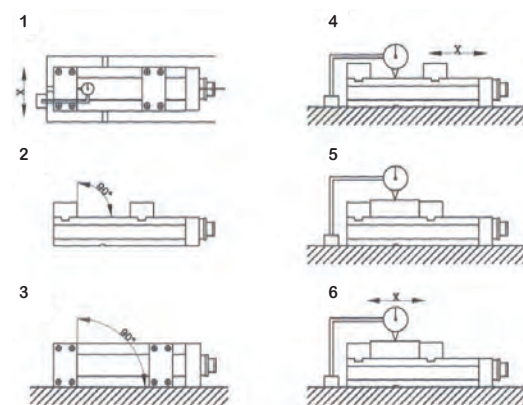
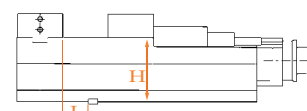

●定壓裝置：

1. 夾持力可以預先設定，將六角板手插入定壓裝置之缺口，調整至所需要之夾持力刻度，即可重複使用相同的夾持力。
2. 一般最適用的夾持力刻度為 **4**

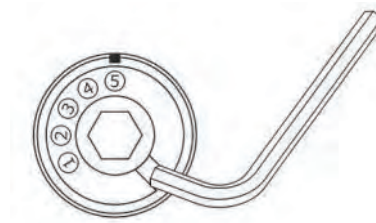

● 定壓裝置
● PRESSURE SYSTEM

●PRESSURE SYSTEM：

1. Clamping force can be set up in advance, using hexagon wrench to insert into the gap of pressure system. Then, it can be adjusted to the clamping force for specific demand and allowed to repeat use the same clamping force.
2. Generally clamping force is suitable scale **4**

MODEL	夾持力(刻度) Clamping Force (Scale)					開口範圍 Clamping Range
	1	2	3	4	5	
JQV-160S	1000	2000	3000	4000	5000	0~235
JQV-160M	1000	2000	3000	4000	5000	0~275
JQV-160	1000	2000	3000	4000	5000	0~305
JQV-160L	1000	2000	3000	4000	5000	0~355
JQV-200L	1000	2000	3500	4500	6000	0~405

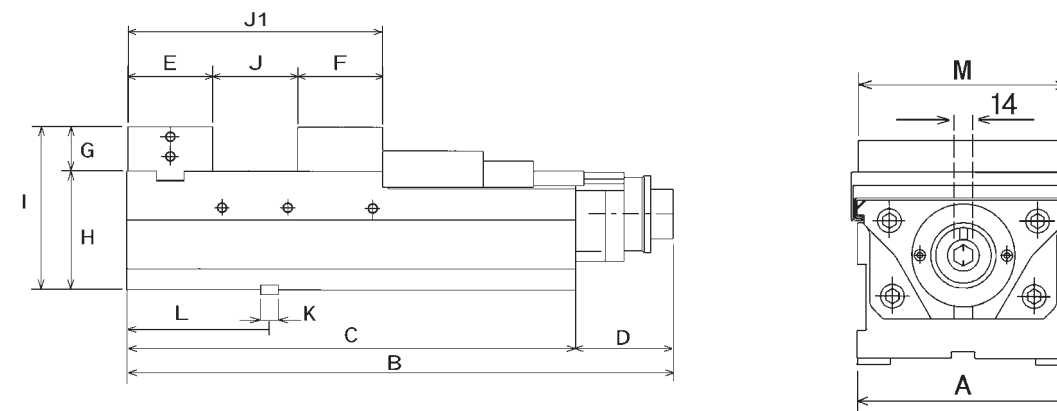
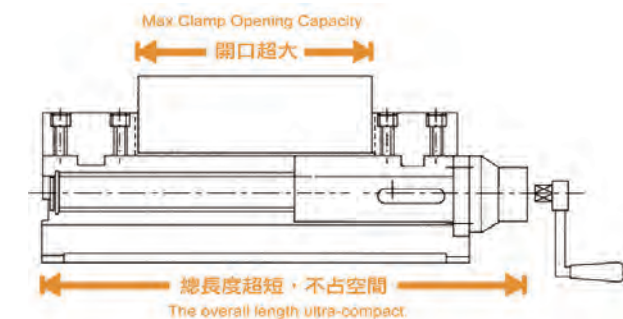

MODEL	A	B	C	D	E	F	G	H	I	J	J1	K	L	M	夾持力 Clamping Force	N.W
JQV-160S	161	515	416	99	86	86	50	105	155	235	405	18	145	159.5	5000kgf	55kg
JQV-160M	161	555	456	99	86	86	50	105	155	275	445	18	145	159.5	5000kgf	57kg
JQV-160	161	585	486	99	86	86	50	105	155	305	475	18	145	159.5	5000kgf	60kg
JQV-160L	161	635	536	99	86	86	50	100	150	355	525	18	145	159.5	5000kgf	66kg
JQV-200L	202	710	611	99	102	98	70	110	180	405	605	18	176	199.5	6000kgf	103kg